



HYDREMA



Hydrema 707G Series

ARTICULATED COMPACT DUMP TRUCKS

Innovative earthmoving since 1959

Since 1959 Hydrema has developed, manufactured, sold and serviced high-tech construction machines. Efficient, innovative and high-quality machines. Our products distinguish themselves from other products on the market through their technical and physical capabilities. Very well suited to perform specialized tasks in construction and installation work.

 **HYDREMA**





HYDREMA 707G SERIES:

Compact, with superb visibility - like no other.

The 707G Series is a new type of compact articulated dump truck, designed from the ground up to improve safety for operators and let them focus on the task at hand.

Sometimes being different is a good thing. The Hydrema 707G Series is different, innovative, safer and more agile than most dump trucks in its class.

Stable

The Hydrema 707G Series offers all the benefits of a larger rear tip ADT, but with the compact size of a traditional site dumper. The 707G Series is a scaled-down version of an articulated machine, but in the 7-ton class, with record low ground pressure.

The 707G Series is built with the same unique and proven high stability chassis design as the 912F Series, with its low centre of gravity and the unique Hydrema articulation pivot point with oscillation and double hydraulic stabilisers, that provide the operator with unmatched stability.

The design ensures that the front and rear wheels are running in the same track, while the standard twin tires give outstanding traction with minimum ground damage.

Combined with a low turning radius of just 5.1 m, the pivot point, which is centrally placed, increases maneuverability and the position characteristics in areas with limited space.

Operator friendly

Designed with one-step entry for easy access, user-friendly controls and joystick operation already familiar from the 912F series. The spacious cabin with 360° visibility, ensure the best working conditions for the operators.

Fuel-saving stage V engine

The Hydrema 707G Series comes in two models with Cummins F3.8 Stage V engines in sizes of 55 kW (75 HP) and 90 kW (122 HP) respectively; the more powerful version being named the Power+.

The 90kW/Power+ requires AdBlue in order to comply with the Stage V standard regulation, which the 55kW does not. Therefore, the Power+ model includes a 19L AdBlue tank.

Combined with the new stop/start function and a hydrostatic transmission that provides fully variable speeds up to 34 km/h, the 707G Series is both effective and fuel-efficient.





Perfect for tight spaces and sensitive surfaces

The compact design, along with smart features like the 180° MultiTip - enables the 707G Series to work in very tight spaces and crowded construction sites.

The unique combination of a high level of stability, hydrostatic transmission in 3 driving modes with outstanding traction and lots of power provides the 707G Series with exceptional driving abilities even in rough, hilly and muddy conditions.

Combined with its low ground pressure of just 83kPa (12psi), when fully loaded with 7.2 tons and equipped with the optional 700mm wide tires, the 707G Series is designed to work on sensitive surfaces.

Together with tracking of the wheels, this ensures minimal ground damage which is ideal for working on sensitive surfaces like golf courses, landscaping and for environmental work.

Rental friendly

Very easy to operate, equipped with multiple safety features, a fuel-efficient engine and low maintenance costs, the 707G Series is well-suited as a rental machine for a wide range of applications.

Safety 24-7

2 front facing LED working lights on the cab roof are standard. An optional extra pair of LED working lights can be mounted

to increase visibility and safety during low light conditions.

Furthermore, additional LED light packages are available with the option of installation of up to 4 rear-facing LED working lights to the dump truck body and 2 for the rear chassis to create better visibility.

For safety reasons, Optional flashing orange LED lights can be installed both at the front and rear of the machine.



ADVANTAGES

- One-step entry for easy access.
- Fuel efficient Cummins F3.8 Stage 5 engine.
- High mobility due to center pivot steering and hydraulic stabilizers.
- The cab provides superb all-round visibility, is operator friendly, safe and robust.
- Low loading height with MultiTip, that matches even a small mini-excavator.

EASY UNLOADING:

Unload with precision and on the move.

The combination of high mobility, stability, MultiTip and speed makes the 707G a safe and efficient work mate for the operator.

Unload in no time

The tipping time of just 6 seconds up and 5 seconds down, enables the operator to unload quickly. This not only speeds up the whole work process but also enhances the effectiveness of the dump truck.

The dump body is produced in durable, high-tensile steel which provides, great strength. It is designed with rounded corners which helps wet and sticky material to slide off easily when tipping.

Precise and flexible unloading

To increase the flexibility and effectivity of the 707G Series, our 180° MultiTip is a standard feature on both versions. The feature allows the body to turn 90 degrees to each side and deliver the material with high precision.

The MultiTip not only eases the workflow, as you can unload the payload sideways e.g. into a trench while moving forward, But also allows you to work in areas with limited space.

Greater efficiency with Auto Body Return

With the optional Auto Body Return function, the dump body is automatically lowered back onto the chassis with a push of a button.

In other words, the operator does not have to look back when the body returns to its position. Instead, the operator can move on to the next task while the body lowers itself into resting position. It saves valuable time and allows the operator to focus on what happens in front of the truck.

Stable drive even on inclines

The low centre of gravity of the 707G Series dump truck and excellent weight distribution between the chassis parts provide superior stability, even on steep inclines regardless of whether the dump truck is loaded or empty.

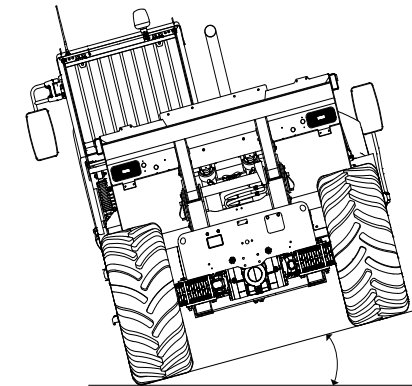

Maximum driving inclination
(Slope angle where the machine overturns).

| Tire option | 500 mm | | 600 mm | | 700 mm | |
|-----------------|--------|--------|--------|--------|--------|--------|
| | EMPTY | LOADED | EMPTY | LOADED | EMPTY | LOADED |
| Going straight | 42° | 34° | 42° | 34° | 42° | 35° |
| Turning up-hill | 40° | 31° | 40° | 31° | 41° | 31° |





OPERATORS CAB:

One-step access, improved safety and 360° visibility.



Protecting the operator

With the unique one-step entry for easy access to the very robust ROPS/FOPS approved cab that measures a height of just 8'4" ft in, we have developed a safe workspace, where the operator is comfortably seated.

Despite the driver's low position in the cab, he can still see over the body when looking backwards while seated in the mechanical or air-suspended seat (optional) and operating the machine with the multi-joystick.

The combination of an adjustable steering column and the multi-joystick control integrated into the right armrest creates the best possible working conditions for the operator.

A great view

The 707G Series is one of the safest dump trucks of this kind on the market. The combination of a rearview camera and the front-facing cab provides superb 360° all-round visibility and meets the ISO standards 5006 and 14401.

Another advantage compared to traditional site-dumpers, is that the payload never blocks the view, which not only increases safety and visibility, but also the efficiency of the 707G Series dump truck.

Air-Conditioning

The cab has a heating and fresh air system with integrated cooling and automatic temperature control. The air is distributed through 3 front nozzles, 2 rear nozzles and 2 vents in the footwell.





MACHINE CONFIGURATION:

Multiple Choice.

Form your own CityKit

With the low loading height of just 6'2"ft in, the 707G Series will match even a small mini excavator, making it perfect for assisting in utility work. The option of equipping the 707G Series with a tow hitch and connect a trailer will allow you to carry a mini excavator and take your work to the streets with your own CityKit.

Tire options

Depending on requirements, there are several different tire options available for the 707G-Series.

All the tires offer good off-road characteristics with an excellent grip that maximise traction performance.

The standard tire is the 500/60 - 22.5. The options are a 600/50 - 22.5 or the 700/40 - 22.5 for very low ground pressure.

Working on golf courses a special grass-friendly tire with extremely low ground pressure is the better option.

All tyre options stay within 8'4" ft in width, so the dump truck can be registered for driving on public roads* fully loaded. (*Regional dependent).

MultiChassis and Flatbed

The 707G series are also available in Multi-Chassis and Flatbed versions. The Multi-Chassis version creates the opportunity to equip the machine with variety of attachments like a salt spreader, concrete mixer, snow blade, broom etc.

The Flatbed version will transform the 707G Series into a utility vehicle that can help transport heavy equipment or supplies. Dependant on the tire choice, you can access difficult locations with various attachments, equipment and/or supplies.

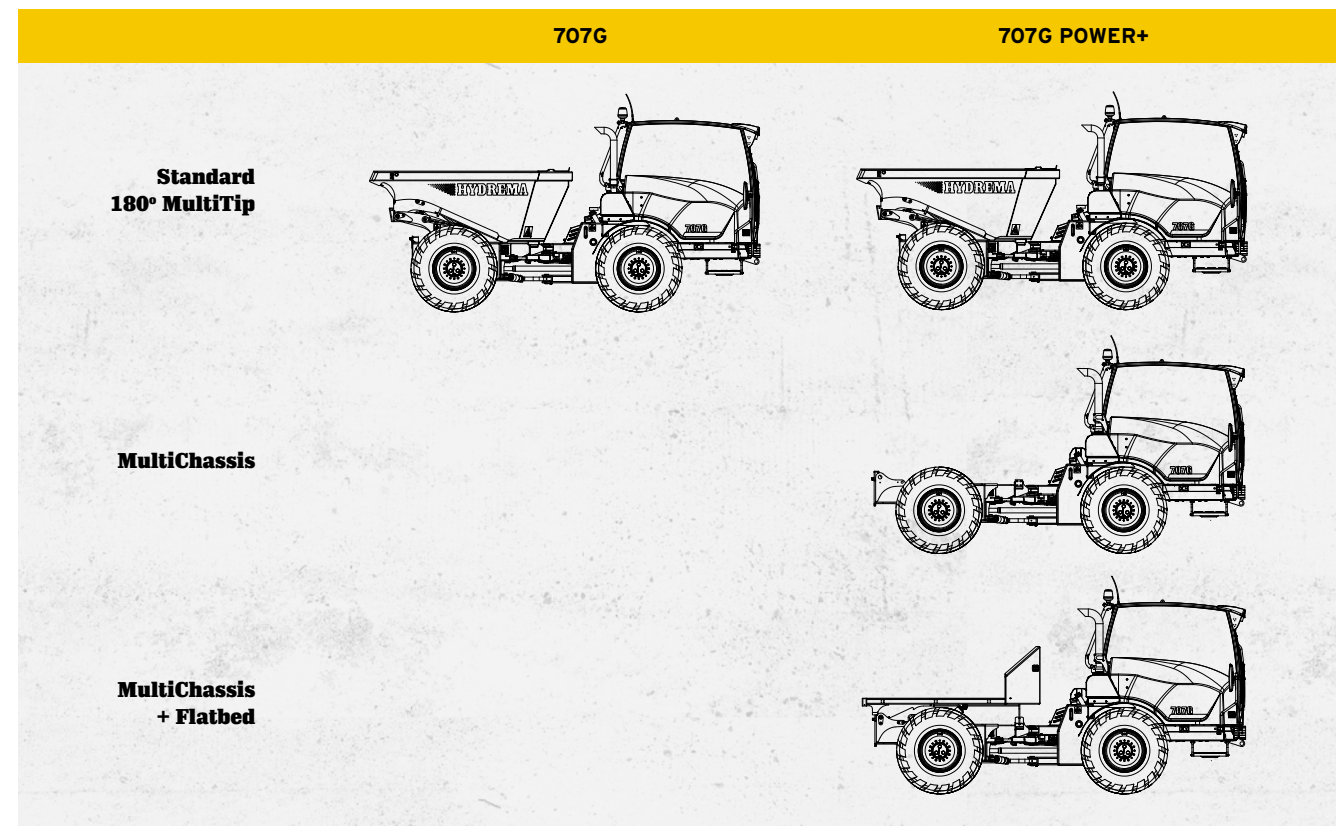



SERVICE & MAINTENANCE:

Service access made easy.

Maximize the uptime with ground level access, quick servicing and online monitoring through Hydrema Telematics.

Easy service access

When conducting service and maintenance, accessing the engine is made easy with the electronic opening of the bonnet, with a simple push on a button, placed behind the right front wheel. The large bonnet opening allows full and safe access to the engine compartment.

From ground level, you can access the different service points and check; the engine, the oil levels, the hydraulic system, the filters etc.

By conducting daily and correct maintenance, you also ensure a long service life and avoid unnecessary breakdowns.

Hydrema Telematics

The 707G can be equipped with the new Hydrema Telematics tracking system. A data collection tool which collects information from the machine via sensors and electronics.

Users can individually log in to the online portal and gain access to the downloaded data from the engine, transmission and other key components along with real-time reports of the working hours and the location of the machine.

By analysing the collected data, the owner or operator can optimize both the operational and financial control of the machine.

The Hydrema Telematics system can help diagnose problems, display alarm codes, and other vital data from the machine via the online portal, so the Hydrema service-team can diagnose faults rapidly and precisely.

Battery and fuses

The battery isolator is placed right below the battery box in the front left side fender, where also access to batteries and fuses are located behind a hatch.



MACHINE DATA:

Specifications.

Dimensions.

Chassis

Articulated chassis with center pivot point and two double acting hydraulic stabilizers. The stabilizers gives high stability when driving and tipping. The fuel and hydraulic tanks are integrated in the front frame. Pivot oscillation +/- 12 °.

Axles

The axles have planetary hub reduction, and separate oil reservoirs in the hubs. The front axle has an automatic limited slip differential lock, and the rear axle has a hydromechanical differential lock. The front axle has integrated reduction gear for hydraulic motor.

Engine

707G: Cummins F3.8 Stage 5 with DOC and DPF. 16 valve Common rail turbo diesel engine with intercooler, electronic variable turbocharger and EGR with cooling. Max. Power: 75 hp (55 kW) at 1500 rpm. Max. Torque 400 Nm at 1300 rpm.

707G Power+: Cummins F3.8 Stage 5 with DOC, DPF and SCR-catalysts with AdBlue additive. 16 valve Common rail turbo diesel engine with intercooler and electronic variable turbocharger. Max. Power 122 hp (90 kW) at 2000 rpm. Max. Torque 500 Nm at 1500 rpm.

Both engine versions have stop/start system, which stops the engine after idling for a set period of time (adjustable in the interval 2-500 s). The engine turns on again automatically when the operator activates the throttle.

Transmission

Hydrostatic Transmission where a 89cc variable piston pump transmission powers a 210cc variable piston motor. 100% variable speed. 3 driving modes: **Creep** - max speed 4.6 mile/h. This makes it possible to adjust the speed precisely even at low speeds. **Normal driving mode** - Max speed of 21 mile/h reached at 2200 rpm. **ECO** - max speed of 18.6 mile/h reached at 1900 rpm. Provides increased comfort when driving on road, because the max speed is reached at lower engine revs. In all three driving modes, the Cruise Control can be engaged in order to retain a fixed speed. Constant 4 wheel drive.

Steering

Hydrostatic load sensing pivot steering with two double acting cylinders, priority valve and integrated emergency steering. Steering cylinders with damping. Max steering angle +/- 38°.

Hydraulic System

Hydraulic pump with 15.6 gal/min for tipping and steering. Priority valve for steering. Separate pump for brakes and stabilizers.

Noise levels

LpA: 72 dB(A) (inside cab)
LwA: 101 dB(A) (outside cab)

Electric System

Standard 24V system with 70 Amp. alternator. Batteries: 2x 12V, 100Ah.

Body

4.6 yd³ robot-welded body in high tensile steel. Tipping angle: 69° (the bottom of the body is tipping 45° in relation to horizontal).

Fuel

Fuel tank: 20.6 gal.
AdBlue tank: 5 gal (Power+ only).
Integrated into the front chassis.

MultiTip

Compact body swivel system, driven by two double acting cylinders. The system makes it possible to dump the load continuously over a 180° slew range. Robust system mounted on a large slewing ball bearing. Tipping function via two powerful double acting cylinders, which ensures that the body is pulled down regardless of the machine's inclination. Tipping time: 6 s up / 5 s down.

Brakes

Dual circuit hydraulic servo system, with oil immersed brake discs at all 4 wheels. The brakes are self-adjusting and maintenance free. The parking brake is a maintenance free electrohydraulic fail-safe brake activating the brake discs in the front axle.

Operators Cab

Spacious ROPS/FOPS approved cab with suspension and excellent view. Mechanical or air suspended seat. Adjustable steering column and multi-joystick control. A/C as standard.

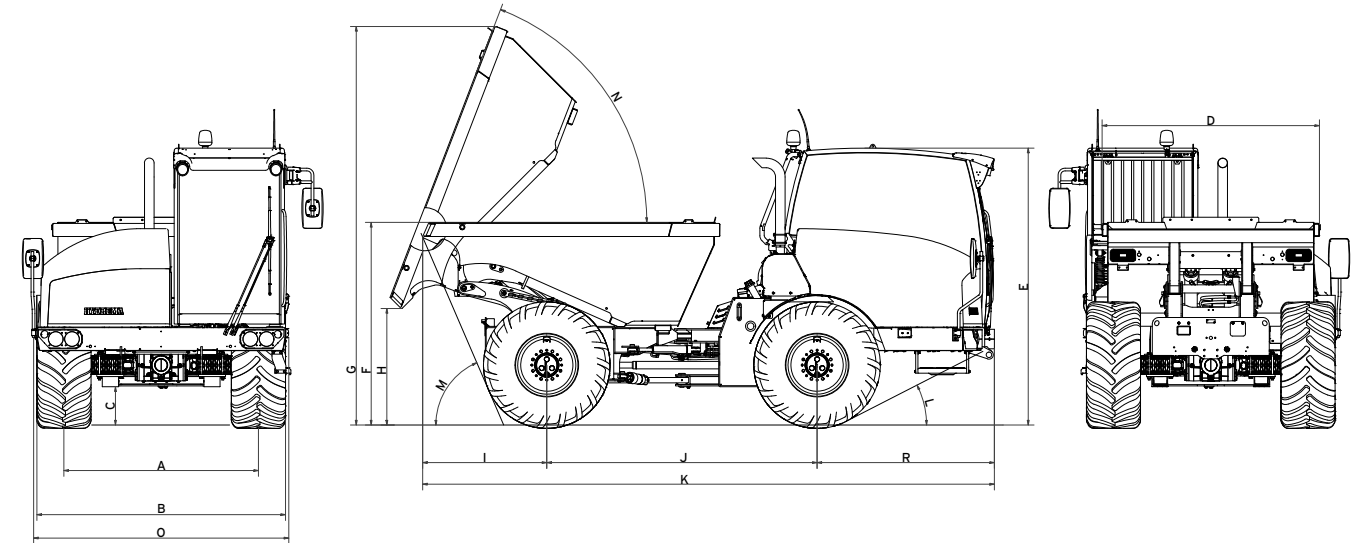

| | | 707G | | | 707G Power+ | | | 707G Power+ MultiChassis | | 707G Power+ MultiChassis + Flatbed | |
|----------------------------|-----------------|-------------|-------------|-------------|-------------|-------------|-------------|--------------------------|-------------|------------------------------------|-------------|
| | | 500/60-22.5 | 600/50-22.5 | 700/40-22.5 | 500/60-22.5 | 600/50-22.5 | 700/40-22.5 | 500/60-22.5 | 700/40-22.5 | 500/60-22.5 | 700/40-22.5 |
| Tires | | | | | | | | | | | |
| Engine power | hp (kW) | 75 (55) | 75 (55) | 75 (55) | 122 (90) | 122 (90) | 122 (90) | 122 (90) | 122 (90) | 122 (90) | 122 (90) |
| SCR catal. with Ad-blue | | | | | x | x | x | x | x | x | x |
| Total weight | lb | 26,125 | 26,235 | 26,345 | 26,235 | 26,345 | 26,455 | | | 23,479 | 23,590 |
| Unladen weight | lb | 11,795 | 11,905 | 12,015 | 11,905 | 12,015 | 12,125 | 9,811 | 9,921 | 11,354 | 11,464 |
| Load capacity | lb | 14,330 | 14,330 | 14,330 | 14,330 | 14,330 | 14,330 | | | | |
| Body capacity (heaped) | yd ³ | 4.6 | 4.6 | 4.6 | 4.6 | 4.6 | 4.6 | | | | |
| Turning radius | ft in | 16'9" | 16'9" | 16'9" | 16'9" | 16'9" | 16'9" | 16'9" | 16'9" | 16'9" | 16'9" |
| Ground pressure (loaded) | psi | 16.8 | 14 | 12 | 16.8 | 14 | 12 | | | | |
| A. Track | ft in | 5'10" | 5'10" | 6' | 5'10" | 5'10" | 6' | 5'10" | 5'10" | 5'10" | 5'10" |
| B. Total width | ft in | 7'9" | 7'10" | 8'4" | 7'9" | 7'10" | 8'4" | 7'9" | 8'4" | 7'9" | 8'4" |
| C. Ground Clearance | ft in | 1'2" | 1'2" | 1'2" | 1'2" | 1'2" | 1'2" | 1'2" | 1'2" | 1'2" | 1'2" |
| D. Width, dumper body | ft in | 6'7" | 6'7" | 6'7" | 6'7" | 6'7" | 6'7" | | | 7'5" | 7'5" |
| E. Max height | ft in | 8'5" | 8'5" | 8'5" | 8'5" | 8'5" | 8'5" | 8'5" | 8'5" | 8'5" | 8'5" |
| F. Loading height | ft in | 6'2" | 6'2" | 6'2" | 6'2" | 6'2" | 6'2" | | | 4'3" | 4'3" |
| G. Height with raised body | ft in | 12'1" | 12'1" | 12'1" | 12'1" | 12'1" | 12'1" | | | 10'11" | 10'11" |
| H. Tipping clearance | ft in | 3'6" | 3'6" | 3'6" | 3'6" | 3'6" | 3'6" | | | 2'11" | 2'11" |
| I. Overhang, rear | ft in | 3'9" | 3'9" | 3'9" | 3'9" | 3'9" | 3'9" | | | 3'5" | 3'5" |
| J. Wheel base | ft in | 8'2" | 8'2" | 8'2" | 8'2" | 8'2" | 8'2" | 8'2" | 8'2" | 8'2" | 8'2" |
| K. Overall length | ft in | 17'4" | 17'4" | 17'4" | 17'4" | 17'4" | 17'4" | 16'5" | 16'5" | 16'12" | 16'12" |
| L. Departure angle, front | ° | 27 | 27 | 27 | 27 | 27 | 27 | 27 | 27 | 27 | 27 |
| M. Departure angle, rear | ° | 69 | 69 | 69 | 69 | 69 | 69 | | | | |
| N. Tipping angle | ° | 69 | 69 | 69 | 69 | 69 | 69 | | | 55 | 55 |
| R. Overhang, front | ft in | 5'5" | 5'5" | 5'5" | 5'5" | 5'5" | 5'5" | 5'5" | 5'5" | 5'5" | 5'5" |

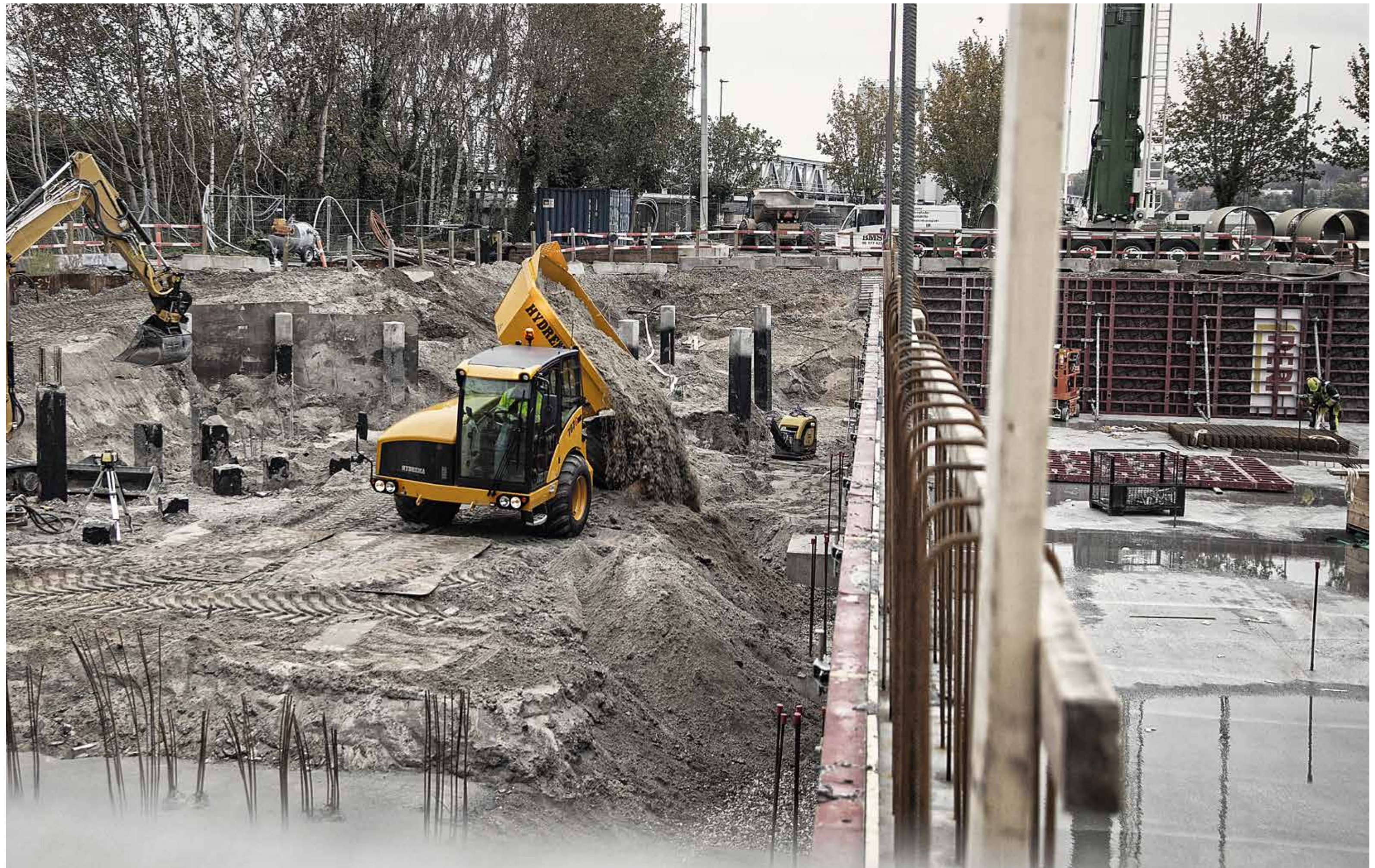

Subject to change. Photos may be shown with optional equipment. 0855561-02/2020

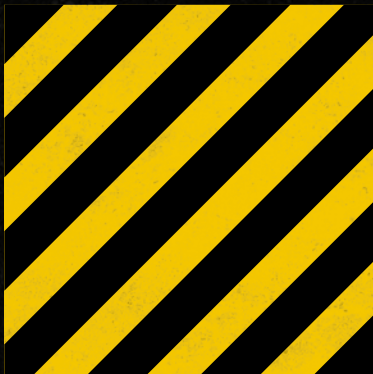

HYDREMA US INC.
Call +1 404 614 1747

MORE INFO
www.hydrema.us

 **HYDREMA**